

VIRGINIA STANDARDS OF LEARNING

Spring 2007 Released Test

GRADE 5 READING

Form R0117, CORE 1

Property of the Virginia Department of Education

©2007 by the Commonwealth of Virginia, Department of Education, P.O. Box 2120, Richmond, Virginia 23218-2120. All rights reserved. Except as permitted by law, this material may not be reproduced or used in any form or by any means, electronic or mechanical, including photocopying or recording, or by any information storage or retrieval system, without written permission from the copyright owner. Commonwealth of Virginia public school educators may reproduce any portion of these released tests for non-commercial educational purposes without requesting permission. All others should direct their written requests to the Virginia Department of Education, Division of Student Assessment and School Improvement, at the above address or by e-mail to Student_Assessment@doe.virginia.gov.

Directions

Read the passage. Then read each question about the passage. Decide which is the best answer to each question. Mark the space on your answer document for the answer you have chosen.

SAMPLE

“Mrs. Johnson is my favorite teacher,”
Maria told her mother. “I really enjoy the
lessons in her class.”

In this paragraph, the word enjoy means —

- A** like
- B** hear
- C** notice
- D** save

Directions: Read the story and answer the questions that follow.

Shebu and the Long-Haired Goat



- 1 Shebu was a gentle young man who lived with his parents. He was very quiet and seemed to live in a world of his own. Though he was happy, his parents worried about him. They were growing old. How would he make his way in the world? The time had come to send him out on his own.
- 2 On Shebu's eighteenth birthday, his father gave him a beautiful goat named Moonlight. The goat had long, silky, white fur. Father said, "Take this goat. You must never hurt the goat or sell her—but, if you are wise, she can help you earn money. When you come home, you should have gold coins in your pocket."
- 3 Shebu's mother gave him a bundle of food. With tears in their eyes, Shebu's parents sent him on his way. Shebu walked through the forest, Moonlight always at his side. In grassy fields Moonlight ate without worries, but Shebu could not live on grass. As his food ran out, Shebu became concerned. The time had come to think about earning money for his living. How could he earn his way in the world?
- 4 One day Shebu and Moonlight found a river, and beside the river were several young ladies. One of them approached Shebu and offered him water from a cup. Gratefully he drank the water and thanked her, asking her what her name was. She told him that her name was Junali, meaning "night of shining stars."
- 5 "Your goat has beautiful fur," said Junali. "Its silky hairs are like the strands I have seen in the finest of rugs."

- 6 "Where do they make these rugs?" asked Shebu.
- 7 "In the big village down the road," she replied.
- 8 Thanking her, Shebu took Moonlight several miles down the road to the big village. An idea had taken shape in the young man's mind. Upon arriving in the town, he asked where he could find the barber. The barber cut off Moonlight's fur, and Shebu gathered the silken hairs together and took them to the shop of the nearest weaver of rugs.
- 9 As they made their way home, Moonlight danced and pranced in the meadows. Without her heavy coat, she felt cool and light. Shebu was not worried. He knew that by the time the cold of winter came, her long white hair would be regrown.
- 10 Shebu's parents greeted him with great joy when he returned. Not only was he safe and wealthy, but he had proven he could take care of himself. They were happy about his new circumstances. He'd found his way and returned with gold too!
- 11 Shebu always remembered Junali, who had helped him simply by noticing the beauty of his goat's fur. Later he would meet Junali again—but that, my friend, is another story.

1 Read this sentence from the first paragraph.

They were growing old.

What does the word growing mean as it is used in this sentence?

- A** blooming
- B** appearing
- C** raising
- D** becoming

2 How does Moonlight come into Shebu's life?

- F** Shebu's friend Junali finds her.
- G** Shebu finds her wandering in the countryside.
- H** A neighbor gives her to Shebu in exchange for work.
- J** She is a birthday gift from Shebu's father.

3 Where do Shebu and Junali meet?

- A** By a river
- B** In a rug shop
- C** At his parents' house
- D** In the big village

4 How does Junali help Shebu?

- F** She brings him food.
- G** She gives him a good idea.
- H** She takes him into town.
- J** She gives him some money.

5 Read this part of a sentence from paragraph 8.

Shebu gathered the silken hairs together

In which word does -en mean the same as it does in silken?

- A gentle
- B golden
- C garment
- D general

6 If a paragraph were added after paragraph 8, it would *most* likely take place in which setting?

- F By the river
- G In the rug shop
- H At Shebu's home
- J In the barber shop

7 In paragraph 9, Moonlight "danced and pranced in the meadows" because —

- A she was happy to leave home with Shebu
- B her hunger was finally satisfied
- C she loved being away from the village
- D her heavy fur had been removed

8 Read this sentence from paragraph 9.

He knew that by the time the cold of winter came, her long white hair would be regrown.

In which word does re- mean the same as it does in regrown?

- F** reasonable
- G** restaurant
- H** reviewed
- J** relatives

9 Shebu receives the gold mentioned in paragraph 10 from —

- A** Junali
- B** the barber
- C** his parents
- D** the weaver

10 The author included the last paragraph to —

- F** support an opinion
- G** suggest an interesting future
- H** introduce a new character
- J** explain a problem

11 By the end of the story, Shebu has become more —

- A** desperate
- B** humorous
- C** obedient
- D** confident

12 Which question presents the main problem in this story?

- F** How will Shebu make his own way in the world?
- G** How will Shebu’s parents find the right gift for him?
- H** How will Shebu save Moonlight from danger?
- J** How will Shebu find a good wife?

13 If the writer added information about what kind of food Shebu’s mother gave him for his journey, it could *best* be added to paragraph —

- A** 1
- B** 2
- C** 3
- D** 4

Directions: Read the article and answer the questions that follow.

The Amazing Hummingbird

1 This bird has feathers that look like sparkling jewels in the sunlight. It flies so fast its wings are a blur, and it knows more tricks than a stunt pilot. What is this tiny creature? The hummingbird!

2 How fast does the hummingbird fly? Well, most hummingbirds beat their wings from 55 to 80 times a second! The rapid flapping makes a humming sound. This buzzing noise is what earned the bird its name.

3 This swift wing speed does not just make an interesting sound, though. Speedy wings help the hummingbird in many important ways. A hummingbird can zip straight up or dive down. It can fly sideways and backwards. It can even fly upside down! This fancy flying helps this tiny bird get its food.

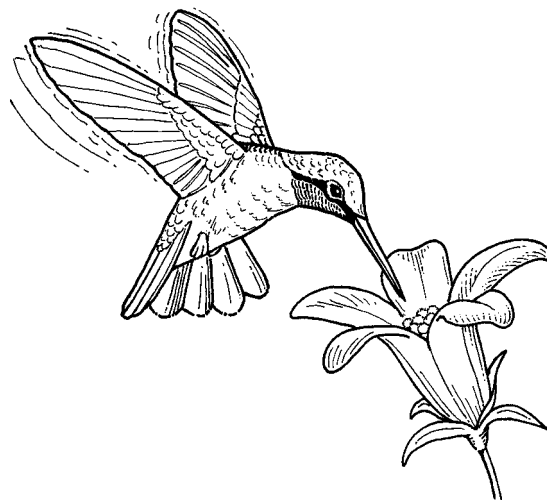

4 The hummingbird eats nectar, the sugary juice found inside most flowers. Because it is too large to land on the petals, it must hover in mid-air while it dines at a bright red, orange, or pink flower. Its small size and fast wing speed make hovering possible. Since it cannot land on the flower, the hummingbird has a special way to reach its food. It uses its long, narrow bill and tongue to reach deep into the center of a flower and lick up the liquid sugar. Then the hummingbird quickly darts sideways to the next waiting blossom.

5 Being one of the swiftest birds around is hard work. The hummingbird's heart beats from 200 to 1,200 times every minute. That's remarkable, especially since a human heart beats an average of 72 times a minute. The hummingbird needs plenty of energy to zoom from flower to flower. To get enough energy, a hummingbird must eat about every ten minutes. Most hummingbirds will eat foods like tree sap and insects, but they like nectar the most. Nectar from flowers is mostly sugar. The sugar gives a hummingbird the quick bursts of energy it needs to keep moving. These tiny birds require trips to about 1,000 to 2,000 different flowers a day for food.

6 The hummingbird mother raises her family by herself. She builds a nest from bits of bark, moss, and other plant materials. She also uses the stretchy silk from spider webs. On the outside, most hummingbird nests are about the size of a quarter. Before long, two eggs fill the nest. Each egg is the size of a bean.

- 7 When the eggs hatch, the baby hummingbirds are blind and featherless. Mom works hard to feed them, bringing nectar and insects to put in their hungry mouths. As the babies grow, the nest stretches. About three weeks later, the young hummingbirds are ready to leave their cozy home. The mother follows them for several weeks to make sure they eat. Then the little birds are on their own.
- 8 Before winter arrives, many hummingbirds migrate. Some fly tremendous distances. A biologist named Gayle Brown studied these interesting birds. She put bands on their legs to track them. One banded hummingbird was on Vancouver Island near Washington. A few weeks later, scientists in southern New Mexico caught the same bird. That’s a long way for such a small creature to travel. Scientists say some hummingbirds migrate all the way from Alaska to Mexico, a distance of 2,700 miles.
- 9 Hummingbirds come in different sizes. The Cuban bee hummingbird is the smallest. It weighs about as much as two paper clips. Even the giant hummingbird is only the size of a sparrow. These birds may be small, but size has never stopped them—not for a second.

14 In paragraph 4, what does nectar mean?

- F** the liquid
- G** the leaf
- H** the stem
- J** the blossom

15 What is the main idea of paragraph 5?

- A** Hummingbirds are found in New Mexico.
- B** Hummingbird eggs are the size of a bean.
- C** Hummingbirds need to eat often to get enough energy.
- D** Hummingbirds will sometimes eat tree sap and insects.

16 Read this sentence from the article.

She also uses the stretchy silk from spider webs.

In which word does -y mean the same as it does in stretchy?

- F** tasty
- G** birthday
- H** daily
- J** happy

17 Hummingbirds fly in all of the following ways EXCEPT —

- A** quickly
- B** silently
- C** sideways
- D** backwards

18 Gayle Brown put bands on hummingbirds because she wanted to —

- F** see how far they fly
- G** know how much they grow
- H** know what flowers they like best
- J** find where they sleep

19 Hummingbirds stay in the air while they eat because —

- A** the flowers can sometimes be harmful
- B** they need to go to the next flower quickly
- C** the other hummingbirds want the sugar
- D** they cannot land on the flower

20 If the author included information about a hummingbird’s favorite flowers, it would belong in paragraph —

- F** 1
- G** 3
- H** 4
- J** 7

21 Which paragraph in the article could have the heading “Mother Hummingbird’s Job”?

- A** 2
- B** 5
- C** 6
- D** 8

22 Which word from the article has a word part meaning “without”?

- F** important
- G** featherless
- H** tremendous
- J** distances

23 To locate Vancouver Island, a student should look in —

- A** an almanac
- B** a glossary
- C** an atlas
- D** a thesaurus

**Turn the page
and
continue working.**

Directions: Read the story and answer the questions that follow.

Grandpa and the Gyroscope

1 David put a few more books from Grandpa’s study into the large, brown box. “This one’s full, Grandpa. What are you doing with these books, anyway?”

2 “These are the ones I can’t take with me,” Grandpa said. “Besides, I’ve read them already. From now on, I want to read new books.”

3 Grandpa was moving out of his house. He said he was tired of taking care of such a big place. To David, this was a sad day. Ever since he was born, he had come to that house to visit his grandfather. He had learned to ride his bike on the front walk. He had his first all-night camp out in the backyard. He couldn’t believe that soon, someone else would be living here.

4 “Take a look at this, David,” Grandpa said. He wiped dust off a small cardboard box, then pulled out an odd metal object. It had two rings around a metal wheel on a straight rod. “Remember this?” asked Grandpa.

5 “What is it?”

6 “A gyroscope¹. You and your sister used to play with it. It was your father’s when he was a boy.” He wound the string around the center rod that held the gyroscope on its metal stand and pulled the string. The wheel in the center began to spin while the outer rings did not move and remained stationary. As David watched it, the memories returned. One summer, he and his sister stayed with Grandpa for a month. They spent many mornings sitting on the front porch experimenting with as many gyroscope tricks as they could imagine. It was a fun time. But what good were memories?

7 Later that day, David’s uncles started loading boxes and old furniture into a moving truck.

8 David asked, “Where’s all this stuff going?”

9 “I’ll donate it to a group that helps the needy. Grandpa doesn’t want it,” said Uncle Pete. He rubbed David’s head.

10 Hauling boxes into the truck, David read their labels. They said things like “books,” “clothes,” “records,” and “linens.” Yet to David, the boxes all contained the same thing: a past that was slipping away. Probably by now, even Grandpa’s gyroscope was in one of these boxes. Looking at them, though, he couldn’t tell which one.

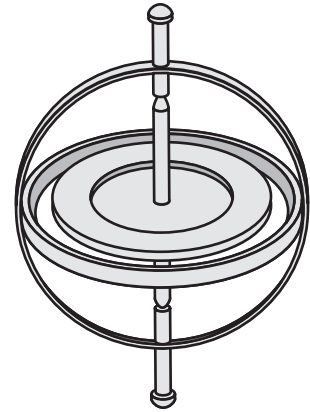

- 11 In the front hallway, a few boxes and suitcases were stacked at the base of the polished wooden railing. The pile was all that was left. David sat on the stairs and held his head in his hands.
- 12 Grandpa walked in the front door. David swallowed hard and took a deep breath. He did not want to seem upset. "Grandpa, are you sure you want to leave? I could live here with you and help you take care of the place."
- 13 The old man laughed. "You are a good boy. I know change is hard, but sometimes it's necessary."
- 14 He walked over to the boxes and pulled something out. It was the gyroscope box from earlier. Grandpa put it in the boy's hands. "I want you to have this, to help you remember."
- 15 David's eyes brightened. "Thanks, Grandpa." He hugged the old man. "I'm going to miss this house."
- 16 David went outside and sat watching while the moving truck, now fully loaded, drove away. He set the gyroscope down on its stand and pulled the long string. There, with the sunlight shining off its metal curves, the gyroscope spun and spun and spun.

¹ gyroscope – a device with a spinning wheel, which is mounted on a base so that its axis can spin freely

24 In paragraph 10, David feels as if the boxes contain —

- F** other toys that Grandpa should have given him
- G** pieces of his childhood that are being taken away
- H** old family secrets that Grandpa is hiding
- J** useful things that should be recycled or reused

25 Grandpa decides to move because he wants —

- A** a front porch
- B** a back patio
- C** a small house
- D** a large study

26 According to the story, what did David do for the first time in Grandpa’s backyard?

- F** He rode a bicycle.
- G** He climbed a tree.
- H** He planted flowers.
- J** He camped out.

27 Read this dictionary entry.

base (bās) *n.* **1.** The support underneath. **2.** The central idea. **3.** The lowest part. **4.** The starting point. **5.** The main station or camp.

Which sentence uses the word base as defined in number 1?

- A** The soldiers’ base of activities was located near the town of Fieldmont.
- B** She travels often, but her home base is Leesburg.
- C** He failed to persuade others because the base of his argument was weak.
- D** For a lighthouse to stand firmly, a strong base is necessary.

28 Which detail first shows that David is starting to feel better?

- F** He lets Grandpa hug him.
- G** He sits down on the front walkway.
- H** His eyes become brighter.
- J** Grandpa laughs at his jokes.

29 How do David and Grandpa differ during *most* of the story?

- A** Grandpa wants to keep old things, and David wants new ones.
- B** David remembers events from the past, and Grandpa forgets most of them.
- C** Grandpa is ready for change, and David wishes their lives could stay the same.
- D** David wants to move to a new place, and Grandpa wants to stay in the same town.

30 Which of these is *most* difficult for David to accept?

- F** The gyroscope will be separated from Grandpa's other belongings.
- G** Grandpa has not invited David and his sister to live in Grandpa's new house.
- H** On moving day his sister has chosen to do something other than help Grandpa.
- J** Strangers will be living in his grandfather's house, and he cannot go there anymore.

31 Which guide words might appear on the same dictionary page as "change"?

- A** celebration – chalk
- B** challenge – chemistry
- C** Charleston – chisel
- D** charm – civilization

**Turn the page
and
continue working.**

Directions: Read the article and answer the questions that follow.

Gentle Giants

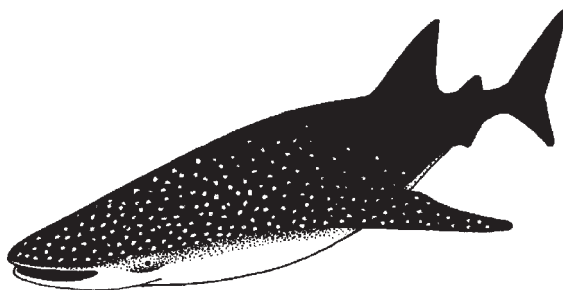

- 1 You probably know that the African elephant is the world's largest land mammal. You might know that the saltwater crocodile is the world's largest reptile. But do you know about the world's largest fish?
- 2 Although the whale shark is our biggest fish and lives in many oceans around the world, few people have even heard of it. Scientists have not been studying whale sharks for very long. Much more needs to be learned about them.
- 3 A whale shark is sometimes called a "gentle giant." It likes to be alone and could not care less about divers or humans. The biggest whale shark that was correctly measured weighed 24,250 pounds and was nearly 40 feet long. This makes it heavier and longer than a school bus. It is a good thing whale sharks are calm and not fierce! Humans do not need to be afraid of them.
- 4 A whale shark has a very broad head with an enormous mouth at the front. The upper half of its body is dark gray with white spots, which may help it blend in with the ocean floor. The skin on its back is thicker and tougher than the skin of any other creature. The outer layer is covered in overlapping skin "scales," or tooth-like bumps. The whale shark seems to wear a suit of armor.
- 5 For such a giant fish, its eyes are small. Unlike many creatures, a whale shark has no eyelids. To close its eyes for protection, the whale shark rolls its eyes and pulls them back into its head. Scientists suspect sight must not be an important sense for the whale shark. They do know that whale sharks have special nerve endings that can locate electromagnetic fields in the water. This helps the whale shark find its food, even in the dark depths of the ocean.
- 6 Inside that enormous mouth are great numbers of very tiny teeth. To count all of them, you'll need to do some math. The whale shark's teeth are arranged in rows. There are between eleven and thirteen rows on each jaw and around three hundred teeth in each row. An average whale shark has at least three thousand teeth. Some whale sharks have even more!

- 7 The whale shark rarely uses its teeth, though. This fish is a filter feeder. It does not chew or bite its food. Large amounts of water are pulled into its mouth and then pushed out through the shark's gills. The gills act like a rake to filter out tiny plankton and krill, the whale shark's food.
- 8 It was only a few years ago that scientists discovered how whale shark babies are born. Strangely enough, a female whale shark hatches eggs inside her body. Then she gives birth to live young called pups. One whale shark was recorded as having three hundred pups!
- 9 For a few months every year, a group of whale sharks comes to Ningaloo Reef, off Western Australia. This gives scientists a wonderful chance to study the huge fish. Whale sharks do live in other oceans of the world, but no one knows their total population. It is possible that our biggest fish may need protecting. It is one of the reasons why scientists continue to learn all they can about these gentle giants.

32 Which two words from the article have the same suffix?

- F** tiny, probably
- G** protection, population
- H** unlike, inside
- J** arranged, hundred

33 In paragraph 6, how does the author help the reader know what the whale shark's mouth looks like?

- A** By quoting scientists
- B** By describing colors
- C** By comparing sizes
- D** By using numbers

34 Which of these could be a heading for paragraph 7?

- F** What Kind of Fish Eat Krill and Plankton?
- G** How Does a Whale Shark Eat?
- H** How Do Different Fish Use Their Gills?
- J** What's Inside a Whale Shark's Head?

35 How are a whale shark's eyes different from *most* animals?

- A** They darken during the day.
- B** They have no eyelids.
- C** They stay closed in water.
- D** They move from side to side.

36 Little is known about whale sharks because scientists —

- F** are not interested in learning about them
- G** find them too difficult to observe
- H** do not know the best places to find them
- J** have studied them for only a short time

37 Whale sharks do *not* depend completely on their eyesight because they —

- A** use their sense of smell to locate krill and plankton
- B** have a special way to sense where food is located
- C** find food by listening for the sound of smaller fish
- D** follow other sharks to find their source of plankton

38 Which sentence about the article *best* supports the idea that whale sharks are gentle?

- F** They have small eyes.
- G** They leave divers alone.
- H** They give birth to live young.
- J** They have special nerve endings.

39 What happens when a whale shark needs to protect its eyes?

- A** Its skin stretches over its eyes.
- B** Its eyes roll back into its head.
- C** Its nerves tell the eyes to close.
- D** Its eyes shrink to a smaller size.

40 This article would *most likely* be found in a book titled —

- F** *My Life on the Sea: The Diary of a Sailor*
- G** *Facts About Australia's Reefs and Beaches*
- H** *Getting to Know the Sea's Unusual Animals*
- J** *Larger Than Life: Great Creatures of the Sky*



Answer Key-5062-R0117

Test Sequence Number	Correct Answer	Reporting Category	Reporting Category Description
1	D	001	Use word analysis strategies and information resources
2	J	002	Demonstrate comprehension of printed materials
3	A	002	Demonstrate comprehension of printed materials
4	G	002	Demonstrate comprehension of printed materials
5	B	001	Use word analysis strategies and information resources
6	G	002	Demonstrate comprehension of printed materials
7	D	002	Demonstrate comprehension of printed materials
8	H	001	Use word analysis strategies and information resources
9	D	002	Demonstrate comprehension of printed materials
10	G	002	Demonstrate comprehension of printed materials
11	D	002	Demonstrate comprehension of printed materials
12	F	002	Demonstrate comprehension of printed materials
13	C	002	Demonstrate comprehension of printed materials
14	F	001	Use word analysis strategies and information resources
15	C	002	Demonstrate comprehension of printed materials
16	F	001	Use word analysis strategies and information resources
17	B	002	Demonstrate comprehension of printed materials
18	F	002	Demonstrate comprehension of printed materials
19	D	002	Demonstrate comprehension of printed materials
20	H	002	Demonstrate comprehension of printed materials
21	C	002	Demonstrate comprehension of printed materials
22	G	001	Use word analysis strategies and information resources
23	C	001	Use word analysis strategies and information resources
24	G	002	Demonstrate comprehension of printed materials
25	C	002	Demonstrate comprehension of printed materials
26	J	002	Demonstrate comprehension of printed materials
27	D	001	Use word analysis strategies and information resources
28	H	002	Demonstrate comprehension of printed materials
29	C	002	Demonstrate comprehension of printed materials
30	J	002	Demonstrate comprehension of printed materials
31	B	001	Use word analysis strategies and information resources
32	G	001	Use word analysis strategies and information resources
33	D	002	Demonstrate comprehension of printed materials
34	G	002	Demonstrate comprehension of printed materials
35	B	002	Demonstrate comprehension of printed materials
36	J	002	Demonstrate comprehension of printed materials
37	B	002	Demonstrate comprehension of printed materials
38	G	002	Demonstrate comprehension of printed materials
39	B	002	Demonstrate comprehension of printed materials
40	H	002	Demonstrate comprehension of printed materials

Grade 5 Reading, Core 1

If you get this many items correct:	Then your converted scale score is:
0	000
1	141
2	179
3	203
4	220
5	234
6	246
7	257
8	266
9	275
10	283
11	291
12	298
13	305
14	311
15	318
16	324
17	331
18	337
19	343
20	349
21	355
22	361
23	368
24	374
25	380
26	387
27	394
28	401
29	408
30	416
31	424
32	432
33	442
34	453
35	465
36	479
37	496
38	519
39	557
40	600

